

## Wi-Fi 5 railway wireless access points/clients



### Features and Benefits

- IEEE 802.11a/b/g/n/ac Wave 2 AP/client
- Concurrent dual-band Wi-Fi with aggregated data rates up to 1.267 Gbps
- Latest WPA3 encryption for enhanced wireless network security
- Designed specifically for rail carriage-to-carriage communication
- Millisecond-level Client-based Turbo Roaming<sup>1</sup>
- Built-in 2.4 GHz and 5 GHz band pass filter for more reliable wireless connections
- -40 to 75°C wide operating temperature range (-T models)

### Certifications



## Introduction

The AWK-3251A-RCC Series industrial wireless AP/client is designed to meet the growing need for faster data transmission speeds through IEEE 802.11ac technology. The Auto Carriage Connection (ACC) feature enables easy deployment of wireless devices and increases the reliability of wireless carriage backbone networks. The AWK-3251A-RCC Series is also optimized for passenger Wi-Fi services and supports up to 120 client connections. The AWK-3251A-RCC Series complies with sections of the EN 50155 standard specifications covering operating temperature, power input voltage, surge, ESD, and vibration, making the product suitable for a variety of industrial applications. The AWK-3251A-RCC Series can be powered via PoE to facilitate flexible deployment and can operate concurrently on both the 2.4 and 5 GHz bands in AP mode.

### Advanced 802.11ac Industrial Wireless Solution

- 802.11a/b/g/n/ac compliant railway dual-band access point with aggregated data rates of up to 1.267 Gbps
- WPA3 encryption for enhanced wireless network security
- Supports ACC technology for wireless inter-carriage connections
- Supports up to 120 device connections and client isolation

### Advanced Wireless Technology

- Seamless roaming with client-based Turbo Roaming<sup>1</sup> for < 150 ms roaming recovery time between APs (Client Mode)

### Industrial Ruggedness

- Integrated antenna isolation designed to provide protection against external electrical interference
- -40 to 75°C wide operating temperature models (-T) for smooth wireless communication in harsh environments

## Specifications

### WLAN Interface

WLAN Standards	2.4 GHz: 802.11b/g/n with 256 QAM support 5 GHz: 802.11a/n/ac Wave 2 with 256 QAM support
Frequency Band for US (20 MHz operating channels)	AWK-3251A-RCC US Models Only: 2.412 to 2.462 GHz (11 channels) 5.180 to 5.240 GHz (4 channels) 5.260 to 5.320 GHz (4 channels) <sup>2</sup> 5.500 to 5.700 GHz (11 channels) <sup>2</sup> 5.745 to 5.825 GHz (5 channels)

1. The Turbo Roaming recovery time indicated herein is an average of test results documented, in optimized conditions, across APs configured with interference-free 20-MHz RF channels, WPA2-PSK security, and default Turbo Roaming parameters. The clients are configured with 3-channel roaming at 100 Kbps traffic load. Other conditions may also impact roaming performance. For more information about Turbo Roaming parameter settings, refer to the product manual.
2. DFS (Dynamic Frequency Selection) channel support: In AP mode, when a radar signal is detected, the device will automatically switch to another channel. However, according to regulations, after switching channels, a 60-second availability check period is required before starting the service.

Frequency Band for UN (20 MHz operating channels)	<p>AWK-3251A-RCC UN Models Only:</p> <p>2.412 to 2.472 GHz (13 channels)</p> <p>5.180 to 5.240 GHz (4 channels)</p> <p>5.260 to 5.320 GHz (4 channels)<sup>3</sup></p> <p>5.500 to 5.700 GHz (11 channels)<sup>3</sup></p> <p>5.745 to 5.825 GHz (5 channels)</p> <p>Available channels change depending on the selected country or region code.</p>
Wireless Security	<p>WEP encryption (64-bit and 128-bit)</p> <p>WPA/WPA2/WPA3-Enterprise (IEEE 802.1X/RADIUS, TKIP, AES)</p> <p>WPA/WPA2/WPA3-Personal</p>
Transmission Rate	<p>2.4 GHz:</p> <p>802.11b: 1 to 11 Mbps</p> <p>802.11g: 6 to 54 Mbps</p> <p>802.11n: 6.5 to 300 Mbps</p> <p>802.11ac: 6.5 to 400 Mbps</p> <p>5 GHz:</p> <p>802.11a: 6 to 54 Mbps</p> <p>802.11n: 6.5 to 300 Mbps</p> <p>802.11ac: 6.5 to 867 Mbps</p>
Transmitter Power for 802.11a	<p>22±1.5 dBm @ 6 Mbps</p> <p>22±1.5 dBm @ 9 Mbps</p> <p>22±1.5 dBm @ 12 Mbps</p> <p>20.5±1.5 dBm @ 18 Mbps</p> <p>20.5±1.5 dBm @ 24 Mbps</p> <p>20.5±1.5 dBm @ 36 Mbps</p> <p>20±1.5 dBm @ 48 Mbps</p> <p>20±1.5 dBm @ 54 Mbps</p>
Transmitter Power for 802.11n (5 GHz)	<p>22±1.5 dBm @ MCS0 20 MHz</p> <p>22±1.5 dBm @ MCS1 20 MHz</p> <p>22±1.5 dBm @ MCS2 20 MHz</p> <p>20±1.5 dBm @ MCS3 20 MHz</p> <p>19.5±1.5 dBm @ MCS4 20 MHz</p> <p>19.5±1.5 dBm @ MCS5 20 MHz</p> <p>19.5±1.5 dBm @ MCS6 20 MHz</p> <p>19±1.5 dBm @ MCS7 20 MHz</p> <p>22±1.5 dBm @ MCS8 20 MHz</p> <p>22±1.5 dBm @ MCS9 20 MHz</p> <p>22±1.5 dBm @ MCS10 20 MHz</p> <p>20±1.5 dBm @ MCS11 20 MHz</p> <p>19.5±1.5 dBm @ MCS12 20 MHz</p> <p>19.5±1.5 dBm @ MCS13 20 MHz</p> <p>19.5±1.5 dBm @ MCS14 20 MHz</p> <p>19±1.5 dBm @ MCS15 20 MHz</p> <p>21±1.5 dBm @ MCS0 40 MHz</p> <p>21±1.5 dBm @ MCS1 40 MHz</p> <p>21±1.5 dBm @ MCS2 40 MHz</p> <p>19.5±1.5 dBm @ MCS3 40 MHz</p> <p>19±1.5 dBm @ MCS4 40 MHz</p> <p>19±1.5 dBm @ MCS5 40 MHz</p> <p>19.5±1.5 dBm @ MCS6 40 MHz</p> <p>19±1.5 dBm @ MCS7 40 MHz</p> <p>21±1.5 dBm @ MCS8 40 MHz</p> <p>21±1.5 dBm @ MCS9 40 MHz</p> <p>21±1.5 dBm @ MCS10 40 MHz</p> <p>19.5±1.5 dBm @ MCS11 40 MHz</p> <p>19±1.5 dBm @ MCS12 40 MHz</p> <p>19±1.5 dBm @ MCS13 40 MHz</p> <p>19±1.5 dBm @ MCS14 40 MHz</p> <p>19±1.5 dBm @ MCS15 40 MHz</p>
Transmitter Power for 802.11ac (5 GHz, Dual Chain)	<p>21.5±1.5 dBm @ MCS0 20 MHz</p> <p>21.5±1.5 dBm @ MCS1 20 MHz</p> <p>21±1.5 dBm @ MCS2 20 MHz</p> <p>20±1.5 dBm @ MCS3 20 MHz</p> <p>19.5±1.5 dBm @ MCS4 20 MHz</p>

3. DFS (Dynamic Frequency Selection) channel support: In AP mode, when a radar signal is detected, the device will automatically switch to another channel. However, according to regulations, after switching channels, a 60-second availability check period is required before starting the service.

	<p>19.5±1.5 dBm @ MCS5 20 MHz  19.5±1.5 dBm @ MCS6 20 MHz  19±1.5 dBm @ MCS7 20 MHz  19±1.5 dBm @ MCS8 20 MHz  21±1.5 dBm @ MCS0 40 MHz  21±1.5 dBm @ MCS1 40 MHz  21±1.5 dBm @ MCS2 40 MHz  19.5±1.5 dBm @ MCS3 40 MHz  19±1.5 dBm @ MCS4 40 MHz  19±1.5 dBm @ MCS5 40 MHz  19±1.5 dBm @ MCS6 40 MHz  19±1.5 dBm @ MCS7 40 MHz  18.5±1.5 dBm @ MCS8 40 MHz  18±1.5 dBm @ MCS9 40 MHz  20±1.5 dBm @ MCS0 80 MHz  20±1.5 dBm @ MCS1 80 MHz  20±1.5 dBm @ MCS2 80 MHz  17±1.5 dBm @ MCS3 80 MHz  17±1.5 dBm @ MCS4 80 MHz  17±1.5 dBm @ MCS5 80 MHz  17±1.5 dBm @ MCS6 80 MHz  17±1.5 dBm @ MCS7 80 MHz  17±1.5 dBm @ MCS8 80 MHz  17±1.5 dBm @ MCS9 80 MHz</p>
Transmitter Power for 802.11b	<p>25.5±1.5 dBm @ 1 Mbps  25.5±1.5 dBm @ 2 Mbps  26±1.5 dBm @ 5.5 Mbps  26±1.5 dBm @ 11 Mbps</p>
Transmitter Power for 802.11g	<p>26±1.5 dBm @ 6 Mbps  26±1.5 dBm @ 9 Mbps  26±1.5 dBm @ 12 Mbps  25±1.5 dBm @ 18 Mbps  25±1.5 dBm @ 24 Mbps  24.5±1.5 dBm @ 36 Mbps  23.5±1.5 dBm @ 48 Mbps  23±1.5 dBm @ 54 Mbps</p>
Transmitter Power for 802.11n (2.4 GHz)	<p>24.5±1.5 dBm @ MCS0 20 MHz  24.5±1.5 dBm @ MCS1 20 MHz  24±1.5 dBm @ MCS2 20 MHz  24±1.5 dBm @ MCS3 20 MHz  23.5±1.5 dBm @ MCS4 20 MHz  23.5±1.5 dBm @ MCS5 20 MHz  22.5±1.5 dBm @ MCS6 20 MHz  22±1.5 dBm @ MCS7 20 MHz  24±1.5 dBm @ MCS8 20 MHz  24.5±1.5 dBm @ MCS9 20 MHz  24±1.5 dBm @ MCS10 20 MHz  24±1.5 dBm @ MCS11 20 MHz  23.5±1.5 dBm @ MCS12 20 MHz  23±1.5 dBm @ MCS13 20 MHz  22±1.5 dBm @ MCS14 20 MHz  21.5±1.5 dBm @ MCS15 20 MHz  24±1.5 dBm @ MCS0 40 MHz  24±1.5 dBm @ MCS1 40 MHz  24±1.5 dBm @ MCS2 40 MHz  24±1.5 dBm @ MCS3 40 MHz  23.5±1.5 dBm @ MCS4 40 MHz  23.5±1.5 dBm @ MCS5 40 MHz  22.5±1.5 dBm @ MCS6 40 MHz  22±1.5 dBm @ MCS7 40 MHz  24±1.5 dBm @ MCS8 40 MHz  24±1.5 dBm @ MCS9 40 MHz  24±1.5 dBm @ MCS10 40 MHz  24±1.5 dBm @ MCS11 40 MHz  23.5±1.5 dBm @ MCS12 40 MHz  23±1.5 dBm @ MCS13 40 MHz  22.5±1.5 dBm @ MCS14 40 MHz  21.5±1.5 dBm @ MCS15 40 MHz</p>

<p>Transmitter Power for 802.11ac (2.4 GHz, Dual Chain)</p>	<p>25±1.5 dBm @ MCS0 20 MHz  25±1.5 dBm @ MCS1 20 MHz  25±1.5 dBm @ MCS2 20 MHz  25±1.5 dBm @ MCS3 20 MHz  24±1.5 dBm @ MCS4 20 MHz  23.5±1.5 dBm @ MCS5 20 MHz  22.5±1.5 dBm @ MCS6 20 MHz  22±1.5 dBm @ MCS7 20 MHz  21.5±1.5 dBm @ MCS8 20 MHz  25±1.5 dBm @ MCS0 40 MHz  25±1.5 dBm @ MCS1 40 MHz  25±1.5 dBm @ MCS2 40 MHz  25±1.5 dBm @ MCS3 40 MHz  24±1.5 dBm @ MCS4 40 MHz  23.5±1.5 dBm @ MCS5 40 MHz  22.5±1.5 dBm @ MCS6 40 MHz  22±1.5 dBm @ MCS7 40 MHz  21.5±1.5 dBm @ MCS8 40 MHz  21±1.5 dBm @ MCS9 40 MHz</p>
<p>Receiver Sensitivity for 802.11a (measured at 5.680 GHz)</p>	<p>Typ. -88 @ 6 Mbps  Typ. -88 @ 9 Mbps  Typ. -85 @ 12 Mbps  Typ. -84 @ 18 Mbps  Typ. -81 @ 24 Mbps  Typ. -77 @ 36 Mbps  Typ. -74 @ 48 Mbps  Typ. -72 @ 54 Mbps</p>
<p>Receiver Sensitivity for 802.11n (5 GHz; measured at 5.680 GHz)</p>	<p>Typ. -88 dBm @ MCS0 20 MHz  Typ. -84 dBm @ MCS1 20 MHz  Typ. -83 dBm @ MCS2 20 MHz  Typ. -80 dBm @ MCS3 20 MHz  Typ. -76 dBm @ MCS4 20 MHz  Typ. -72 dBm @ MCS5 20 MHz  Typ. -70 dBm @ MCS6 20 MHz  Typ. -68 dBm @ MCS7 20 MHz  Typ. -89 dBm @ MCS8 20 MHz  Typ. -87 dBm @ MCS9 20 MHz  Typ. -85 dBm @ MCS10 20 MHz  Typ. -81 dBm @ MCS11 20 MHz  Typ. -78 dBm @ MCS12 20 MHz  Typ. -74 dBm @ MCS13 20 MHz  Typ. -73 dBm @ MCS14 20 MHz  Typ. -71 dBm @ MCS15 20 MHz  Typ. -85 dBm @ MCS0 40 MHz  Typ. -82 dBm @ MCS1 40 MHz  Typ. -79 dBm @ MCS2 40 MHz  Typ. -77 dBm @ MCS3 40 MHz  Typ. -73 dBm @ MCS4 40 MHz  Typ. -69 dBm @ MCS5 40 MHz  Typ. -68 dBm @ MCS6 40 MHz  Typ. -66 dBm @ MCS7 40 MHz  Typ. -87 dBm @ MCS8 40 MHz  Typ. -84 dBm @ MCS9 40 MHz  Typ. -82 dBm @ MCS10 40 MHz  Typ. -79 dBm @ MCS11 40 MHz  Typ. -75 dBm @ MCS12 40 MHz  Typ. -72 dBm @ MCS13 40 MHz  Typ. -70 dBm @ MCS14 40 MHz  Typ. -69 dBm @ MCS15 40 MHz</p>
<p>Receiver Sensitivity for 802.11ac (5 GHz, Dual Chain)</p>	<p>Typ. -89 dBm @ MCS0 20 MHz  Typ. -86 dBm @ MCS1 20 MHz  Typ. -84 dBm @ MCS2 20 MHz  Typ. -81 dBm @ MCS3 20 MHz  Typ. -78 dBm @ MCS4 20 MHz  Typ. -74 dBm @ MCS5 20 MHz  Typ. -72 dBm @ MCS6 20 MHz  Typ. -71 dBm @ MCS7 20 MHz  Typ. -67 dBm @ MCS8 20 MHz  Typ. -86 dBm @ MCS0 40 MHz  Typ. -84 dBm @ MCS1 40 MHz</p>

	<p>Typ. -81 dBm @ MCS2 40 MHz  Typ. -78 dBm @ MCS3 40 MHz  Typ. -75 dBm @ MCS4 40 MHz  Typ. -71 dBm @ MCS5 40 MHz  Typ. -70 dBm @ MCS6 40 MHz  Typ. -69 dBm @ MCS7 40 MHz  Typ. -64 dBm @ MCS8 40 MHz  Typ. -63 dBm @ MCS9 40 MHz  Typ. -84 dBm @ MCS0 80 MHz  Typ. -81 dBm @ MCS1 80 MHz  Typ. -79 dBm @ MCS2 80 MHz  Typ. -76 dBm @ MCS3 80 MHz  Typ. -73 dBm @ MCS4 80 MHz  Typ. -69 dBm @ MCS5 80 MHz  Typ. -67 dBm @ MCS6 80 MHz  Typ. -65 dBm @ MCS7 80 MHz  Typ. -61 dBm @ MCS8 80 MHz  Typ. -60 dBm @ MCS9 80 MHz</p>
Receiver Sensitivity for 802.11b (measured at 2.437 GHz)	<p>Typ. -96 dBm @ 1 Mbps  Typ. -92 dBm @ 2 Mbps  Typ. -91 dBm @ 5.5 Mbps  Typ. -88 dBm @ 11 Mbps</p>
Receiver Sensitivity for 802.11g (measured at 2.437 GHz)	<p>Typ. -90 dBm @ 6 Mbps  Typ. -89 dBm @ 9 Mbps  Typ. -88 dBm @ 12 Mbps  Typ. -86 dBm @ 18 Mbps  Typ. -82 dBm @ 24 Mbps  Typ. -79 dBm @ 36 Mbps  Typ. -75 dBm @ 48 Mbps  Typ. -73 dBm @ 54 Mbps</p>
Receiver Sensitivity for 802.11n (2.4 GHz; measured at 2.437 GHz)	<p>Typ. -89 dBm @ MCS0 20 MHz  Typ. -86 dBm @ MCS1 20 MHz  Typ. -84 dBm @ MCS2 20 MHz  Typ. -81 dBm @ MCS3 20 MHz  Typ. -77 dBm @ MCS4 20 MHz  Typ. -73 dBm @ MCS5 20 MHz  Typ. -72 dBm @ MCS6 20 MHz  Typ. -70 dBm @ MCS7 20 MHz  Typ. -91 dBm @ MCS8 20 MHz  Typ. -88 dBm @ MCS9 20 MHz  Typ. -86 dBm @ MCS10 20 MHz  Typ. -82 dBm @ MCS11 20 MHz  Typ. -80 dBm @ MCS12 20 MHz  Typ. -75 dBm @ MCS13 20 MHz  Typ. -74 dBm @ MCS14 20 MHz  Typ. -73 dBm @ MCS15 20 MHz  Typ. -87 dBm @ MCS0 40 MHz  Typ. -84 dBm @ MCS1 40 MHz  Typ. -82 dBm @ MCS2 40 MHz  Typ. -78 dBm @ MCS3 40 MHz  Typ. -75 dBm @ MCS4 40 MHz  Typ. -71 dBm @ MCS5 40 MHz  Typ. -70 dBm @ MCS6 40 MHz  Typ. -68 dBm @ MCS7 40 MHz  Typ. -88 dBm @ MCS8 40 MHz  Typ. -85 dBm @ MCS9 40 MHz  Typ. -83 dBm @ MCS10 40 MHz  Typ. -80 dBm @ MCS11 40 MHz  Typ. -77 dBm @ MCS12 40 MHz  Typ. -73 dBm @ MCS13 40 MHz  Typ. -71 dBm @ MCS14 40 MHz  Typ. -70 dBm @ MCS15 40 MHz</p>
Receiver Sensitivity for 802.11ac (2.4 GHz, Dual Chain)	<p>Typ. -90 dBm @ MCS0 20 MHz  Typ. -87 dBm @ MCS1 20 MHz  Typ. -85 dBm @ MCS2 20 MHz  Typ. -82 dBm @ MCS3 20 MHz  Typ. -79 dBm @ MCS4 20 MHz  Typ. -75 dBm @ MCS5 20 MHz  Typ. -73 dBm @ MCS6 20 MHz</p>

	Typ. -72 dBm @ MCS7 20 MHz Typ. -68 dBm @ MCS8 20 MHz Typ. -88 dBm @ MCS0 40 MHz Typ. -85 dBm @ MCS1 40 MHz Typ. -83 dBm @ MCS2 40 MHz Typ. -80 dBm @ MCS3 40 MHz Typ. -77 dBm @ MCS4 40 MHz Typ. -72 dBm @ MCS5 40 MHz Typ. -71 dBm @ MCS6 40 MHz Typ. -70 dBm @ MCS7 40 MHz Typ. -66 dBm @ MCS8 40 MHz Typ. -64 dBm @ MCS9 40 MHz
WLAN Operation Mode	Access point Client Client-Router Master Slave Sniffer ACC
Antenna Connectors	QMA

### Ethernet Interface

Standards	IEEE 802.3 for 10BaseT IEEE 802.3u for 100BaseT(X) IEEE 802.3ab for 1000BaseT(X) IEEE 802.3at for PoE IEEE 802.1Q for VLAN Tagging IEEE 802.1X for authentication
10/100/1000BaseT(X) Ports (M12 X-coded 8-pin female connector)	1 Supports IEEE 802.3at PoE

### Ethernet Software Features

Management	DHCP Server/Client DNS HTTP IPv4 LLDP SMTP SNMPv1/v2c/v3 Syslog TCP/IP Telnet UDP VLAN MXconfig
Security	HTTPS/SSL RADIUS SSH
Time Management	SNTP Client
<b>Firewall</b>	
Filter	ICMP MAC address IP protocol Port-based

### Serial Interface

Console Port	RS-232 8-pin RJ45
--------------	----------------------

### LED Interface

LED Indicators	PWR1, PWR2, PoE, System, LAN, 2.4GHz, 5GHz, SIG
----------------	---

## Input/Output Interface

Digital Inputs	2 Max. input current: 8 mA +13 to +30 V for state 1 +3 to -30 V for state 0
Alarm Contact Channels	Relay output with current carrying capacity of 1 A @ 24 VDC
Buttons	Reset button

## Physical Characteristics

Housing	Metal
IP Rating	IP30
Dimensions	45 x 130 x 118 mm (1.77 x 5.12 x 4.65 in)
Weight	800 g (1.76 lb)
Installation	DIN-rail mounting Wall mounting (with optional kit)

## Power Parameters

Input Current	12-48 VDC, 2.01-0.5 A
Input Voltage	12 to 48 VDC Redundant dual inputs 48 VDC Power-over-Ethernet
Power Connector	1 removable 10-contact terminal block(s)
Power Consumption	24.12 W (max.)

## Environmental Limits

Operating Temperature	Standard Models: -25 to 60°C (-13 to 140°F) Wide Temp. Models: -40 to 75°C (-40 to 167°F)
Storage Temperature (package included)	-40 to 85°C (-40 to 185°F)
Ambient Relative Humidity	5 to 95% (non-condensing)

## Standards and Certifications

EMC	EN 55032/35
EMI	CISPR 32, FCC Part 15B Class A
EMS	IEC 61000-4-2 ESD: Contact: 8 kV; Air: 15 kV IEC 61000-4-3 RS: 80 MHz to 1 GHz: 20 V/m IEC 61000-4-4 EFT: Power: 2 kV; Signal: 2 kV IEC 61000-4-5 Surge: Power: 2 kV; Signal: 2 kV IEC 61000-4-6 CS: 10 V/m IEC 61000-4-8 PFMF: 30 A/m
Safety	IEC 60950-1 IEC 62368-1 UL 62368-1
Railway	EN 50121-4 EN 50155
Railway Fire Protection	EN 45545-2
Radio	EN 300 328, EN 301 489-1/17, EN 301 893, FCC, MIC, TELEC, NCC, RCM, SRRC, IC

## MTBF

Time	838,684 hrs
Standards	Telcordia SR332

## Warranty

Warranty Period	5 years
Details	See <a href="http://www.moxa.com/warranty">www.moxa.com/warranty</a>

## Package Contents

Device	1 x AWK-3251A-RCC Series wireless AP/client
Installation Kit	1 x cap, for RJ45 console port 1 x cap, for M12 Ethernet port 1 x cable holder with screw 1 x DIN-rail kit
Documentation	1 x quick installation guide 1 x warranty card

## Dimensions

Unit: mm (inch)

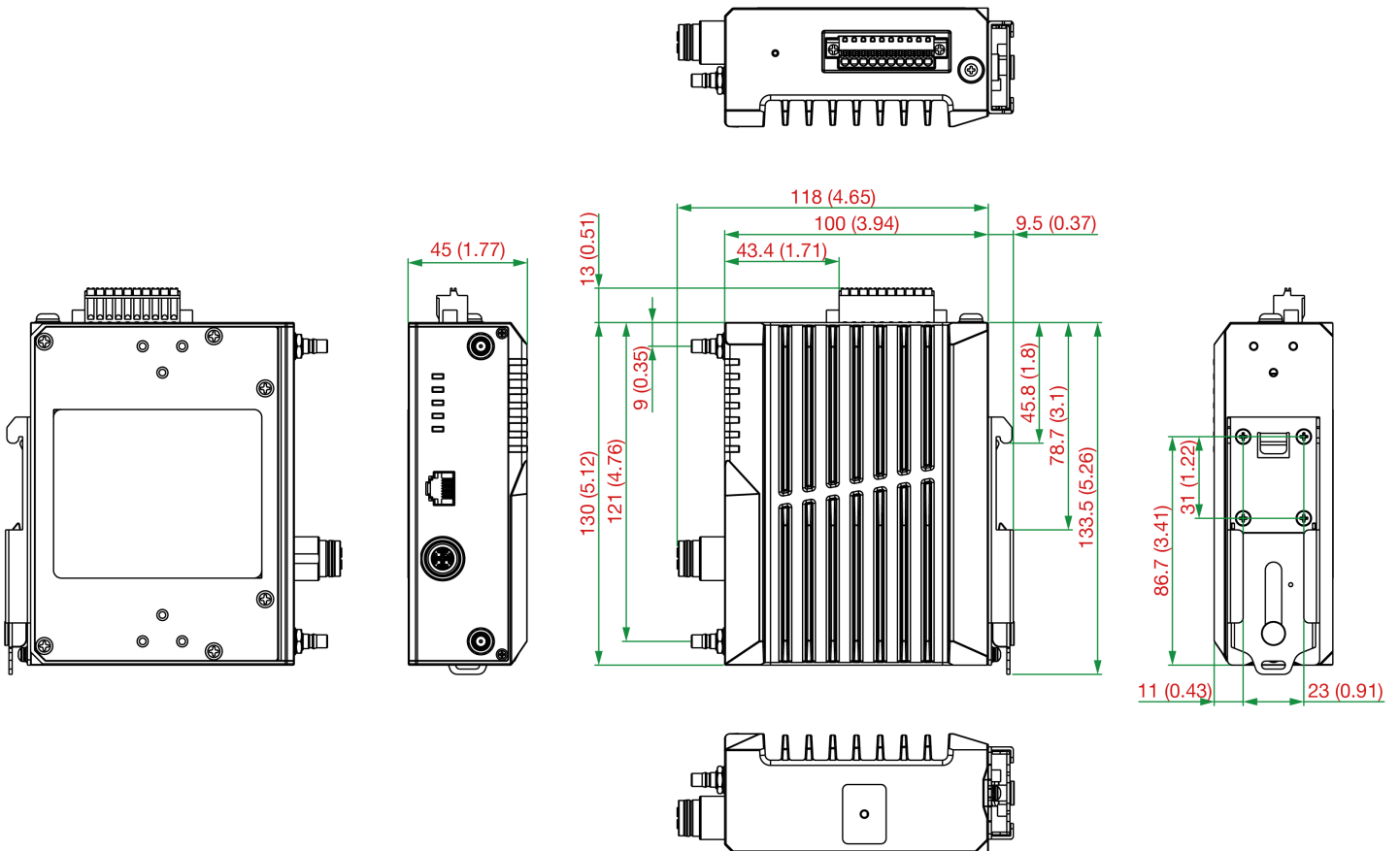

## Ordering Information

Model Name	Band	Operating Temp.	Conformal Coating
AWK-3251A-M12-RCC-US	US	-25 to 60°C	-
AWK-3251A-M12-RCC-US-T	US	-40 to 75°C	-
AWK-3251A-M12-RCC-US-CT-T	US	-40 to 75°C	✓
AWK-3251A-M12-RCC-UN	UN	-25 to 60°C	-

Model Name	Band	Operating Temp.	Conformal Coating
AWK-3251A-M12-RCC-UN-T	UN	-40 to 75°C	-
AWK-3251A-M12-RCC-UN-CT-T	UN	-40 to 75°C	✓

## Accessories (sold separately)

### Wall-Mounting Kits

WK-35-01	Wall-mounting kit with 2 plates (35 x 44 x 2.5 mm) and 6 screws
----------	---

© Moxa Inc. All rights reserved. Updated Oct 04, 2023.

This document and any portion thereof may not be reproduced or used in any manner whatsoever without the express written permission of Moxa Inc. Product specifications subject to change without notice. Visit our website for the most up-to-date product information.